

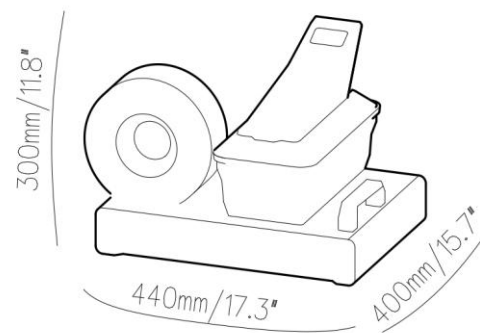

## YB-P16AP FEATURES

Easy to use, light and compact in size, allowing to be carried to any location. P16AP is air pump operated hydraulic crimping machine for repair workshops and field use.



### CONTROL

Manual

### TECHNICAL DATA

Max crimping dia (mm)	10-45
Max crimping dia (inches)	0.39-1.77
Max. crimping force (kN)	955
Max. crimping force (tonnage)	95
Cycle time 10 mm (s)	—
Hose size ID (inches)	1
Dies set series	P16
Max. opening (mm)	+20
Max. opening without dies (mm)	59
Master die D / L (mm)	39/64
Master die D / L (inches)	1.54/2.52
Motor Power	Air pressure

### DIMENSIONS (L x W x H)

Machine (mm)	440X400X300
Machine (inch)	17.3X15.7X11.8
Package (mm)	600X480X450
Package (inch)	23.6X18.9X17.7

### WEIGHT (KG)

N.W.	30
G.W.	42

### P16 Dies:

DieSetNo	Crimping range	ID (mm)	L (mm)
P16/06*	6.0 - 8.0	6	55
P16/08*	8.0 - 10.0	8	55
P16/10*	10.0 - 12.0	10	55
P16/12*	12.0 - 14.0	12	55
P16/14	14.0 - 16.0	14	55
P16/16	16.0 - 19.0	16	55
P16/19	19.0 - 23.0	19	55
P16/23	23.0 - 27.0	23	55
P16/27	27.0 - 31.0	27	65
P16/31	31.0 - 38.0	31	65

\*: Non standard die

