



P16HP



P16HPZ



YB-P16HP/P16HPZ FEATURES

P16HP/P16HPZ is hand pump operated hydraulic crimping machine for repair workshops and field use. Easy to use, light and compact in size, allowing to be carried to any location.

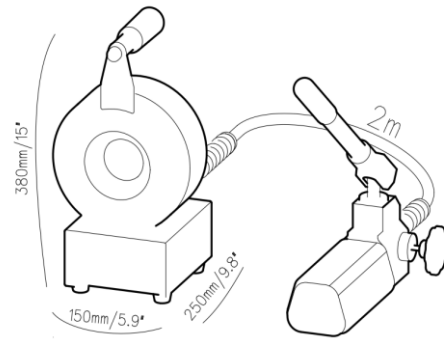
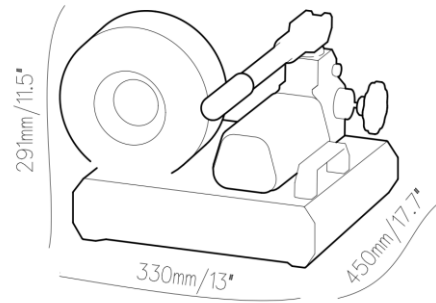

CONTROL

Manual

TECHNICAL DATA

Max crimping dia (mm)	10-45
Max crimping dia (inches)	0.39-1.77
Max. crimping force (kN)	955
Max. crimping force (tonnage)	95
Cycle time 10 mm (s)	—
Hose size ID (inches)	1
Dies set series	P16
Max. opening (mm)	+20
Max. opening without dies (mm)	59
Master die D / L (mm)	39/64
Master die D / L (inches)	1.54/2.52
Motor Power	Hand pump

DIMENSIONS (L x W x H)

P16HP (mm)	330X450X291
P16HP (inch)	13X17.7X11.5
P16HPZ (mm)	150X250X380
P16HPZ (inch)	5.9X9.8X15
Package (mm)	475X430X410
Package (inch)	18.7X16.9X16.1

WEIGHT (KG)

P16HP N. W.	26
P16HP G.W.	34
P16HPZ N. W.	24
P16HPZ G.W.	32

P16 Dies:

DieSetNo	Crimping range	ID (mm)	L (mm)
P16/06*	6.0 - 8.0	6	55
P16/08*	8.0 - 10.0	8	55
P16/10*	10.0 - 12.0	10	55
P16/12*	12.0 - 14.0	12	55
P16/14	14.0 - 16.0	14	55
P16/16	16.0 - 19.0	16	55
P16/19	19.0 - 23.0	19	55
P16/23	23.0 - 27.0	23	55
P16/27	27.0 - 31.0	27	65
P16/31	31.0 - 38.0	31	65

*: Non standard die

