



# Guangzhou YuBen Hydraulic Technology Co., Ltd

Add: A5 Factory, Lanyuan Industrial Zone, No. 8 Xinwu Sixth Street,  
Zhaidong Village, Yongning Street, Zengcheng District, Guangzhou



## CONTROL

Manual

## TECHNICAL DATA

Max crimping dia (mm)	10-54
Max crimping dia (inches)	0.39-2.13
Max. crimping force (kN)	955
Max. crimping force (tonnage)	95
Cycle time 10 mm (s)	—
Hose size ID (inches)	1*4sp
Dies set series	P18
Max. opening (mm)	+20
Max. opening without dies (mm)	68
Master die D / L (mm)	48/64
Master die D / L (inches)	1.89/2.52
Motor Power	Hand pump

## DIMENSIONS (L x W x H)

Machine (mm)	430X450X320
Machine (inch)	16.9X17.7X12.6
Package (mm)	625X505X510
Package (inch)	24.6X19.9X20.1

## WEIGHT (KG)

N. W.	45
G. W.	55

## YB-P18HP FEATURES

P18HP hose-crimping machine has been designed to crimp up to 1" diameter 4-spiral hoses. It is hand pump operated hydraulic crimping machine for repair workshops and field use. Easy to use, light and compact in size, allowing to be carried to any location.

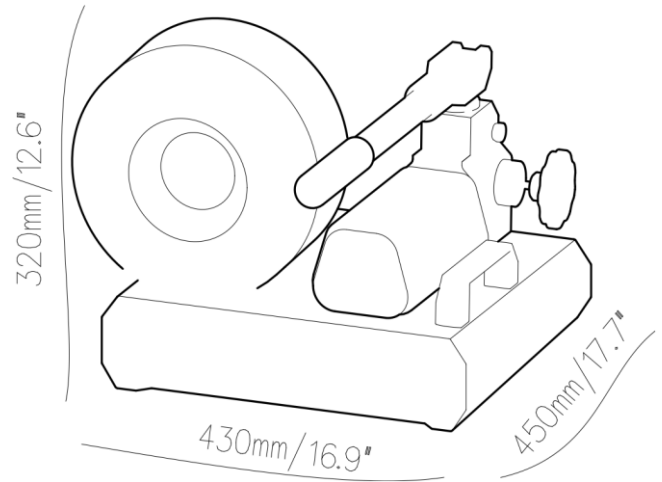

## Dies:

DieSetNo	Crimping range	ID (mm)	L (mm)
P18/06*	6.0 - 8.0	6	55
P18/08*	8.0 - 10.0	8	55
P18/12*	12.0 - 14.0	12	55
P18/14	14.0 - 16.0	14	55
P18/16	16.0 - 19.0	16	55
P18/19	19.0 - 23.0	19	55
P18/23	23.0 - 27.0	23	55
P18/27	27.0 - 31.0	27	65
P18/31	31.0 - 36.0	31	65
P18/36	36.0 - 41.0	36	65
P18/41	41.0 - 47.0	41	65

\*: Non standard die

