



Guangzhou YuBen Hydraulic Technology Co., Ltd

Add: A5 Factory, Lanyuan Industrial Zone, No. 8 Xinwu Sixth Street,
Zhaidong Village, Yongning Street, Zengcheng District, Guangzhou



YB-P20HP FEATURES

YB-P20HP hose-crimping machine has been designed to crimp up to 1 1/2" diameter 4-spiral hoses. It is fast and easy to use. It is manually operated for repair and maintenance needs.

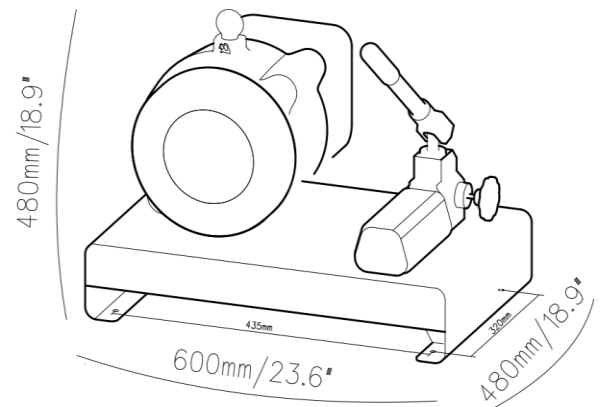

CONTROL

Manual



TECHNICAL DATA

Max crimping dia (mm)	10-61
Max crimping dia (inches)	0.39-2.40
Max. crimping force (kN)	1370
Max. crimping force (tonnage)	137
Cycle time 10 mm (s)	—
Hose size ID (inches)	1 1/2
Dies set series	P20
Max. opening (mm)	+25
Max. opening without dies (mm)	109
Master die D / L (mm)	84/80
Master die D / L (inches)	3.31/3.15
Motor Power	Hand pump

DIMENSIONS (L x W x H)

Machine (mm)	600X480X480
Machine (inch)	23.6X18.9X18.9
Package (mm)	675X630X780
Package (inch)	26.6X24.8X30.7

WEIGHT (KG)

N.W.	78
G.W.	102

P20 Dies:

DieSetNo	Crimping range	ID (mm)	L (mm)
P20/06*	6.0 - 8.0	6	55
P20/08*	8.0 - 10.0	8	55
P20/10*	10.0 - 12.0	10	55
P20/12*	12.0 - 14.0	12	55
P20/14*	14.0 - 16.0	14	55
P20/16	16.0 - 19.0	16	55
P20/19	19.0 - 23.0	19	55
P20/23	23.0 - 27.0	23	55
P20/27	27.0 - 31.0	27	70
P20/31	31.0 - 36.0	31	70
P20/36	36.0 - 41.0	36	75
P20/41	41.0 - 47.0	41	75
P20/47	47.0 - 54.0	47	85
P20/54*	54.0 - 61.0	54	85

*: Non standard die

