



Guangzhou YuBen Hydraulic Technology Co., Ltd

Add:A5 Factory, Lanyuan Industrial Zone, No. 8 Xinwu Sixth Street,
Zhaidong Village, Yongning Street, Zengcheng District, Guangzhou



YB-P32D FEATURES

P32D hose-crimping machine has been designed to crimp up to 2" diameter 4-spiral hoses. And for workshop use. It is fast and easy to use. Control by CNC system.

CNC SYSTEM FEATURES

- ※Setup Max. opening
- ※Correction /Offset
- ※Pressure maintaining time delay function
- ※Setup special die
- ※Quality report
- ※Pressure control
- ※Step crimping
- ※Save crimping data
- ※Counting

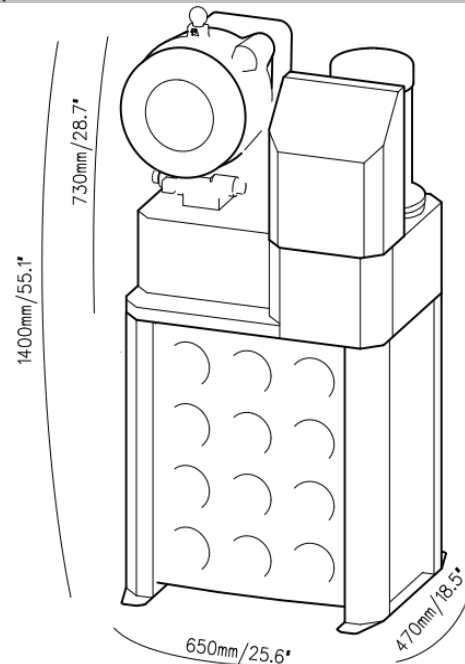

TECHNICAL DATA

Max crimping dia (mm)	10-87
Max crimping dia (inches)	0.39-3.42
Max. crimping force (kN)	2000
Max. crimping force (tonnage)	200
Cycle time 10 mm (s) Tri/Mono	3.3 / 5.5
Hose size ID (inches)	2 (4SH)
Dies set series	P32
Max. opening (mm)	+33
Max. opening without dies (mm)	132
Master die D / L (mm)	99/80
Master die D / L (inches)	3.90/3.15
Motor Tri/Mono (kW/HP)	3.7/5 4/5.3
Oil tank volume (L)	42
Crimping /hour	700/850
Motor Voltage (V) : Tri	200/220/380/440
Motor Voltage (V) : Mono	220/230/240

DIMENSIONS (L x W x H)

Machine (mm)	650X470X1400
Machine (inch)	25.6X18.5X55.1
Package (mm)	880X880X890
Package (inch)	34.6X34.6X35

WEIGHT (KG)

N. W.	305
G. W.	335

CONTROL

- ※Semi-Automatic
- ※Automatic
- ※CNC

STANARD FEATURES

- ※QuickChange-tool
- ※Die racks
- ※Foot pedal **

(**with Automatic continuous crimping function)

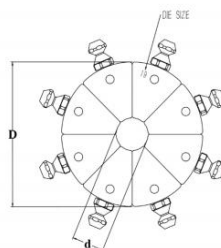

P32Dies:

DieSetNo	Crimping range ID (mm)	L (mm)
P32/06*	6.0 - 8.0	6 55
P32/08*	8.0 - 10.0	8 55
P32/10*	10.0 - 12.0	10 55
P32/12*	12.0 - 14.0	12 55
P32/14	14.0 - 16.0	14 55
P32/16	16.0 - 19.0	16 55
P32/19	19.0 - 22.0	19 55
P32/22	22.0 - 26.0	22 70
P32/26	26.0 - 30.0	26 70
P32/30	30.0 - 34.0	30 70
P32/34	34.0 - 39.0	34 75
P32/39	39.0 - 45.0	39 75
P32/45	45.0 - 51.0	45 90
P32/51	51.0 - 57.0	51 90
P32/57	57.0 - 63.0	57 100
P32/63	63.0 - 69.0	63 100
P32/69	69.0 - 75.0	69 100
P32/74*	74.0 - 80.0	74 100
P32/78*	78.0 - 87.0	78 100

*: Non standard die