



Guangzhou YuBen Hydraulic Technology Co., Ltd

Add: A5 Factory, Lanyuan Industrial Zone, No. 8 Xinwu Sixth Street,
Zhaidong Village, Yongning Street, Zengcheng District, Guangzhou



YB-P32S FEATURES

Yuben P32S hose-crimping machine has been designed to crimp up to 2" diameter 4-spiral hoses. And for workshop use. It is fast and easy to use.

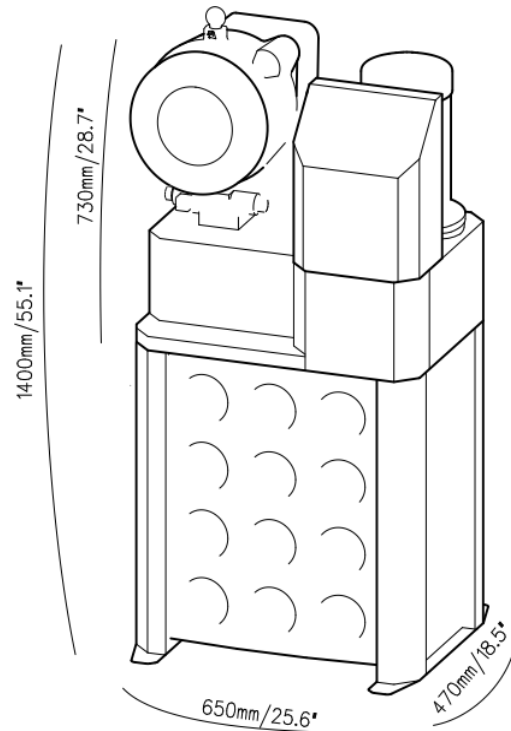

TECHNICAL DATA

Max crimping dia (mm)	10-87
Max crimping dia (inches)	0.39-3.42
Max. crimping force (kN)	2000
Max. crimping force (tonnage)	200
Cycle time 10 mm (s) Tri/Mono	3.3 / 5.5
Hose size ID (inches)	2 (4SH)
Dies set series	P32
Max. opening (mm)	+33
Max. opening without dies (mm)	132
Master die D / L (mm)	99/80
Master die D / L (inches)	3.90/3.15
Motor Tri/Mono (kW/HP)	3.7/5 4/5.3
Oil tank volume (L)	42
Crimping /hour	700/850
Motor Voltage (V): Tri	200/220/380/440
Motor Voltage (V): Mono	220/230/240

DIMENSIONS (L x W x H)

Machine (mm)	650X470X1400
Machine (inch)	25.6X18.5X55.1
Package (mm)	880X880X890
Package (inch)	34.6X34.6X35

WEIGHT (KG)

N. W.	305
G. W.	335

CONTROL

※Semi-Automatic

STANDARD FEATURES

- ※QuickChange-tool
- ※Die racks
- ※Foot pedal

P32Dies:

DieSetNo	Crimping range ID (mm)	L (mm)	L (mm)
P32/06*	6.0 - 8.0	6	55
P32/08*	8.0 - 10.0	8	55
P32/10*	10.0 - 12.0	10	55
P32/12*	12.0 - 14.0	12	55
P32/14	14.0 - 16.0	14	55
P32/16	16.0 - 19.0	16	55
P32/19	19.0 - 22.0	19	55
P32/22	22.0 - 26.0	22	70
P32/26	26.0 - 30.0	26	70
P32/30	30.0 - 34.0	30	70
P32/34	34.0 - 39.0	34	75
P32/39	39.0 - 45.0	39	75
P32/45	45.0 - 51.0	45	90
P32/51	51.0 - 57.0	51	90
P32/57	57.0 - 63.0	57	100
P32/63	63.0 - 69.0	63	100
P32/69	69.0 - 75.0	69	100
P32/74*	74.0 - 80.0	74	100
P32/78*	78.0 - 87.0	78	100

*: Non standard die

