



Guangzhou YuBen Hydraulic Technology Co., Ltd

Add: A5 Factory, Lanyuan Industrial Zone, No. 8 Xinwu Sixth Street,
Zhaidong Village, Yongning Street, Zengcheng District, Guangzhou



YB-P20 FEATURES

YB-P20 hose-crimping machine has been designed to crimp up to 1 1/2" diameter 4-spiral hoses. And for workshop use. It is fast and easy to use.

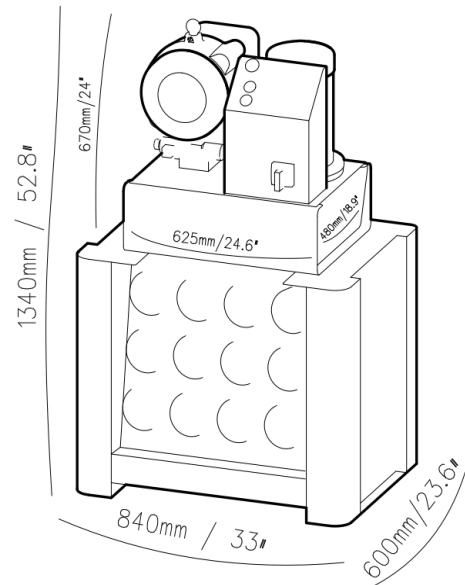

TECHNICAL DATA

Max crimping dia (mm)	10-61
Max crimping dia (inches)	0.39-2.40
Max. crimping force (kN)	1370
Max. crimping force (tonnage)	137
Cycle time 10 mm (s)	3.6
Hose size ID (inches)	1 1/2 (4SH)
Dies set series	P20
Max. opening (mm)	+25
Max. opening without dies (mm)	109
Master die D / L (mm)	84/80
Master die D / L (inches)	3.31/3.15
Motor (kW/HP)	3/4
Oil tank volume (L)	32
Crimping /hour	600/850
Motor Voltage (V) : Tri	200/220/380/440
Motor Voltage (V) : Mono	110/115/220/230/240

DIMENSIONS (L x W x H)

Machine (mm)	840X600X1340
Machine (inch)	33X23.6X52.8
Package (mm)	925X765X890
Package (inch)	36.4X30.1X35

WEIGHT (KG)

N.W.	204
G.W.	227

STANDARD FEATURES

- ✘ QuickChange-tool
- ✘ Die racks
- ✘ Foot pedal

CONTROL

- ✘ Semi-Automatic

P20Dies:

DieSetNo	Crimping range	ID (mm)	L (mm)
P20/06*	6.0 - 8.0	6	55
P20/08*	8.0 - 10.0	8	55
P20/10*	10.0 - 12.0	10	55
P20/12*	12.0 - 14.0	12	55
P20/14	14.0 - 16.0	14	55
P20/16	16.0 - 19.0	16	55
P20/19	19.0 - 23.0	19	55
P20/23	23.0 - 27.0	23	55
P20/27	27.0 - 31.0	27	70
P20/31	31.0 - 36.0	31	70
P20/36	36.0 - 41.0	36	75
P20/41	41.0 - 47.0	41	75
P20/47	47.0 - 54.0	47	85
P20/54*	54.0 - 61.0	54	85

*: Non standard die

